

# Flag & Banner Design Guidelines

## Design Approval Process

**Flag and Banner designs must be approved by the CoA prior to going into production.**

Approval is dependent upon meeting the standards set out in the Design Guidelines.

Designs must be submitted for approval a minimum of 21 days prior to the proposed installation date. Artwork can be submitted as a low-res PDF or jpeg file via email: [events@cityofadelaide.com.au](mailto:events@cityofadelaide.com.au). Please allow up to 7 business days for the design approval.

Banners used in previous years must be in good condition, clean and free of fading, rips or tears if intended to be used again.

The City of Adelaide reserves the right to reject any design that do not meet the design guidelines or if the physical condition does not meet quality standards.

## Notification and Approval

When the design of a flag or banner is deemed satisfactory for public display by the Council and a copy of the required Public Liability Insurance for \$20 million noting City of Adelaide as an Interested Party has been received, the Applicant will be notified in writing. Only at this stage should any manufacturing take place. Applicants are advised not to proceed with printing until written approval is provided. Applicants should allow two working days for this process. Additional time should be allowed if a Development Application is to be processed.

It is important to note, a maximum booking display period of 28 days may be applied during peak event seasons each year (January to March and September to October). Throughout November and December, all flag and banner sites are booked for City of Adelaide Christmas banners and decorations.

Once approval has been granted, and manufacturing is complete, the banners or flags should be rolled up and delivered to the Council's London Road Depot, 10-24 London Road, Mile End, no later than three working days prior to the installation date. This time is necessary in case any adjustments are required to the flags or banners. It is important to note that banners which are delivered flat packed will not be installed.

The Council will assume responsibility for the erection and removal of a set of banners. The banners and flags will also be monitored during the period in which they are on display. Should any damage occur, either from wind or other natural force, or vandalism, which renders a flag or banner unsafe for display, the Council will dismantle banner(s) or flag(s) and notify the owner as soon as practicable.

The Council will not be held liable for any loss or damage that may occur.

## Design Guidelines

**Designs must be approved by the City of Adelaide prior to printing**

Banners are considered a decorative advertising medium. As banners are often an addition to other marketing material, the artwork may need to be altered to suit the banner medium.

Each banner can have a maximum of 10% of the total banner allocated for direct sponsorship recognition, such as a company's logo or naming rights. Image dimensions are scaled from standard banner specifications. The 10% restriction applies to all styles of banners. An example of a banner can be found on page 9 of this document.

To help make the design more effective, it is essential that:

# Flag & Banner Design Guidelines

- One bold striking image or graphic design is used and overall graphics are kept simple.
- Font size should be large enough to ensure readability against a bright sky and legibility from a 50m distance is a travelling vehicle.
- Colour selection is important to guarantee visibility against both the sky and city landscape. White, yellow and other pale colours are not recommended as they soil very easily (if this occurs the client will be responsible for removal and cleaning/repair work that will be conducted at their expense). Black, grey and other extremely dark backgrounds can blend into the general cityscape.
- The title of the event should be included and appear in a clear manner.
- Extended text should only be used where it forms part of the established image of the event and logo.
- Montages and slogans should be avoided as the design will be hard to see from afar.
- Where there are multiple designs an installation plan that includes images of the banners must be provided with the delivery of banners. The City Flags & Banners maps can assist with this process <http://www.cityofadelaide.com.au/city-business/business-support/flags-banners/>
- All Banners must have artwork printed on both sides, excluding O'Connell Street only (single-side only)

## Graphic Content

Because flags and banners must be mounted at least 5 metres above street level, the graphic composition of colour and text needs to be bold and uncomplicated, and able to be read at a distance of up to 50 metres from a moving vehicle. Excessive use of darker colours, or fine text should be avoided.

## Text

Text should be in a font that is legible from a distance. It should be easily distinguishable from the background colour(s) used in the flag or banner. Light coloured text on a dark background has been proved to have the greatest clarity. A minimum recommended font size is lettering an average of 240mm in height. Some recommended fonts are Arial or Garamond although provided the characters are easily legible, there is no limit to the characteristics of the font. Text should be as succinct as possible.

## Colours

The 'Pantone Colour Matching System' guide for printers is widely used, and can be quoted when communicating colour requirements to a printer/manufacturer. The system allows for an infinite palette of colours, although lighter, brighter colours add impact to a design. High degrees of contrast between different coloured elements are effective.

## Subject matter

The primary focus of a flag or banner should be a recreational, sporting or tourist event, or a community based activity or festival and promote the City of Adelaide as a destination for visitation.

Flags or banners with events of a political, religious, marginal or controversial nature as their focus, should be discussed at an early stage and will only be permitted subject to Council approval.

The flags and banners need to reinforce the City's image as the capital of the festival state and convey a sense of activity and vibrancy.

Material deemed to be inappropriate or offensive to the community at large, or to any particular community sector, will not be permitted.

The focus of any banner will always be subject to the consideration and approval of Council.

# Flag & Banner Design Guidelines

In certain circumstances, a proposal may be referred to Council for decision.

## Third party advertising and sponsor logos

Sponsor logos can occupy a maximum of 10% of the total area if only one sponsor is offering sponsorship. If there are a number of companies or organisations sponsoring an event, a maximum of 20% of the area of the flag or banner may be given over to advertising.

## Production Specs & Diagrams

### Construction – Flags

Contemporary Flags are usually comprised of the lighter fabrics such as trilobal, through which ink passes completely. This light fabric does not require wind holes due to the lightness and spacing of the individual fibers.

Traditional Flags are usually fully sewn OR screen printed design on flag bunting material for extended use OR for short-term use flags may be made by screen printing on trilobal. Flags require 2 x 'Engel' fixings to attach to halyards.

### Construction – Banners

Construction should be as sturdy as possible and banners should be made from heavy duty, exterior grade vinyl. Banners should be hemmed and double stitched at their sides, and hemmed and double stitched at their top and bottom ends. When sleeves are attached at the top and bottom ends, the stitching should be properly reinforced. The diameter of the sleeves should be 160mm to allow easy attachment to the brackets.

It is also recommended that 15mm eyelets be incorporated into each corner of the banner, which can strengthen stitching when it is subjected to severe wind loads.

Four 'wind holes' should be let into the fabric to alleviate wind pressure, and reduce the overall stress that wind can impose on both banner and lighting column. The holes should be 50mm in diameter, partially cut into the fabric to create a 'flap' rather than a complete hole. The ends should also be triple stitched.

Banners should be stored flat and each banner should be separated by paper to preserve the ink work, which can 'sweat' from the surface.

### Fixings

In addition to the provision of a finished set of banners, each must be equipped with a correctly designed fixing system. Flags require an 'Engel' fixing so they can be attached to halyards.

Banners require a reinforced sleeve at their top and bottom ends to facilitate their installation. The length of banners can differ in streets such as Melbourne Street and Gouger Street. Similarly, the width of banners across streets varies according to the street. All the standard dimensions are provided with this information.

Where banners across streets are proposed in locations other than those specifically provided by Council, a Development Application may be required indicating, as a minimum, the exact location, proposed dimensions, fixings, an engineer's report if required and a letter of approval from the adjoining building owners. Please note Development Assessment could take approx. 6 weeks. If heritage listed building allow minimum of 10 weeks.

# Flag & Banner Design Guidelines

## Graphic Content & Text

### Ratios of graphic content and text

- Minimum 50% graphic content
- Maximum 20% text content (advertising limited to 50% and rest is graphic design)

### Example

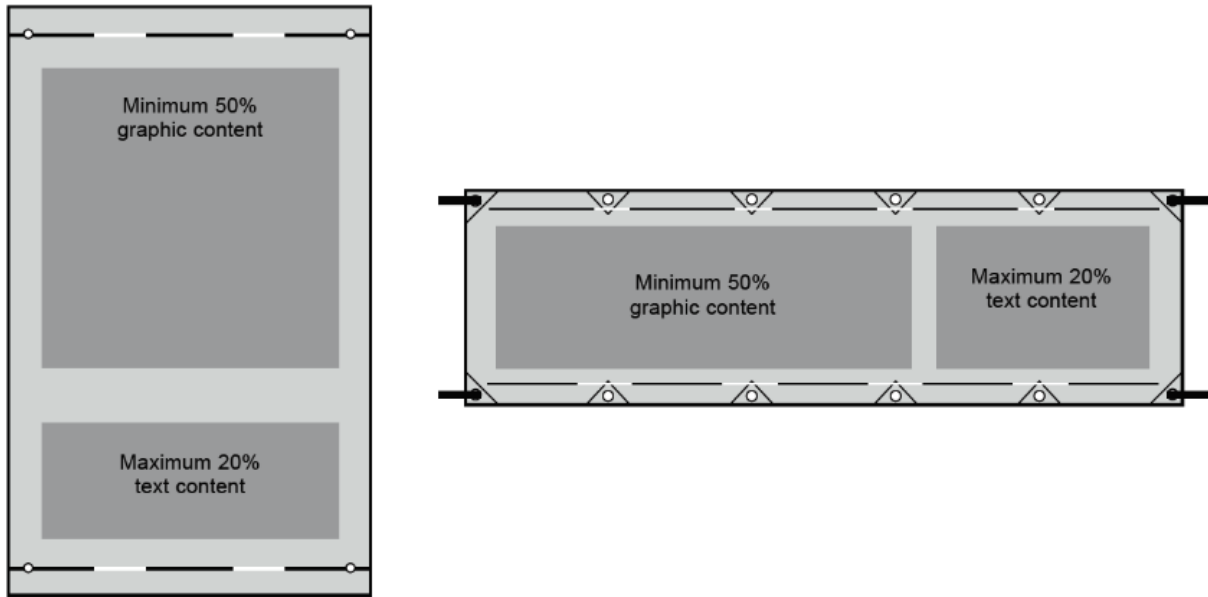

### Third Party Advertising (Sponsor Logos)

- Percentage of advertising provisions
- Third Party Advertising to address use of sponsors logo
- Maximum 10% if one sponsor, 20% maximum space if multiple sponsors

### Example

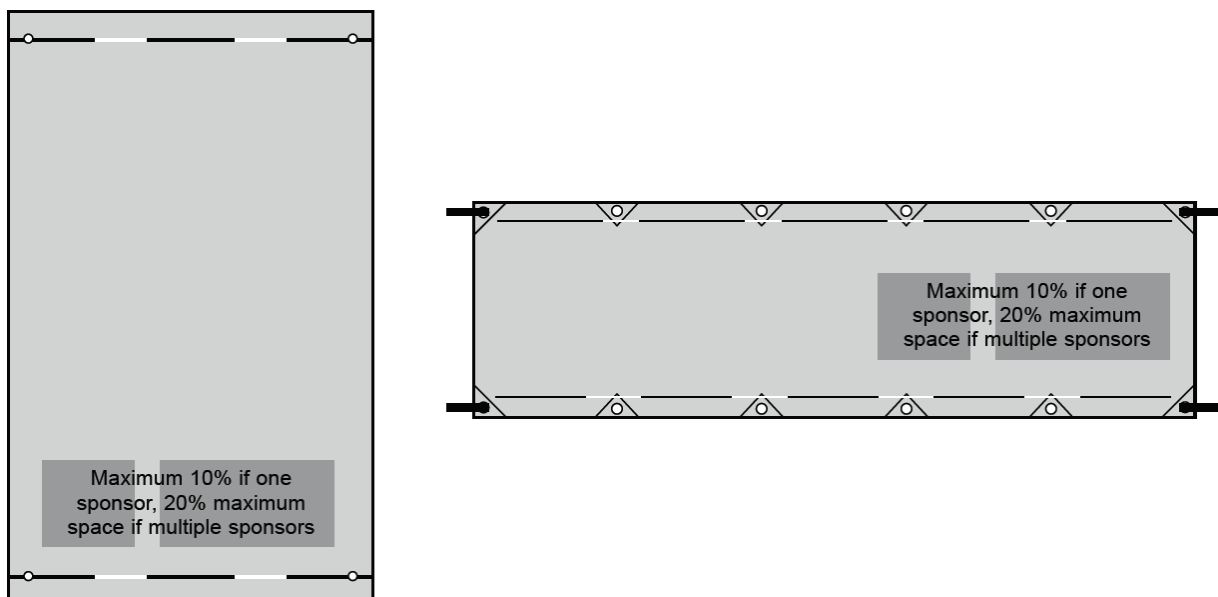

# Flag & Banner Design Guidelines

## City Banners

### O'Connell Street

\*Banners to be single sided

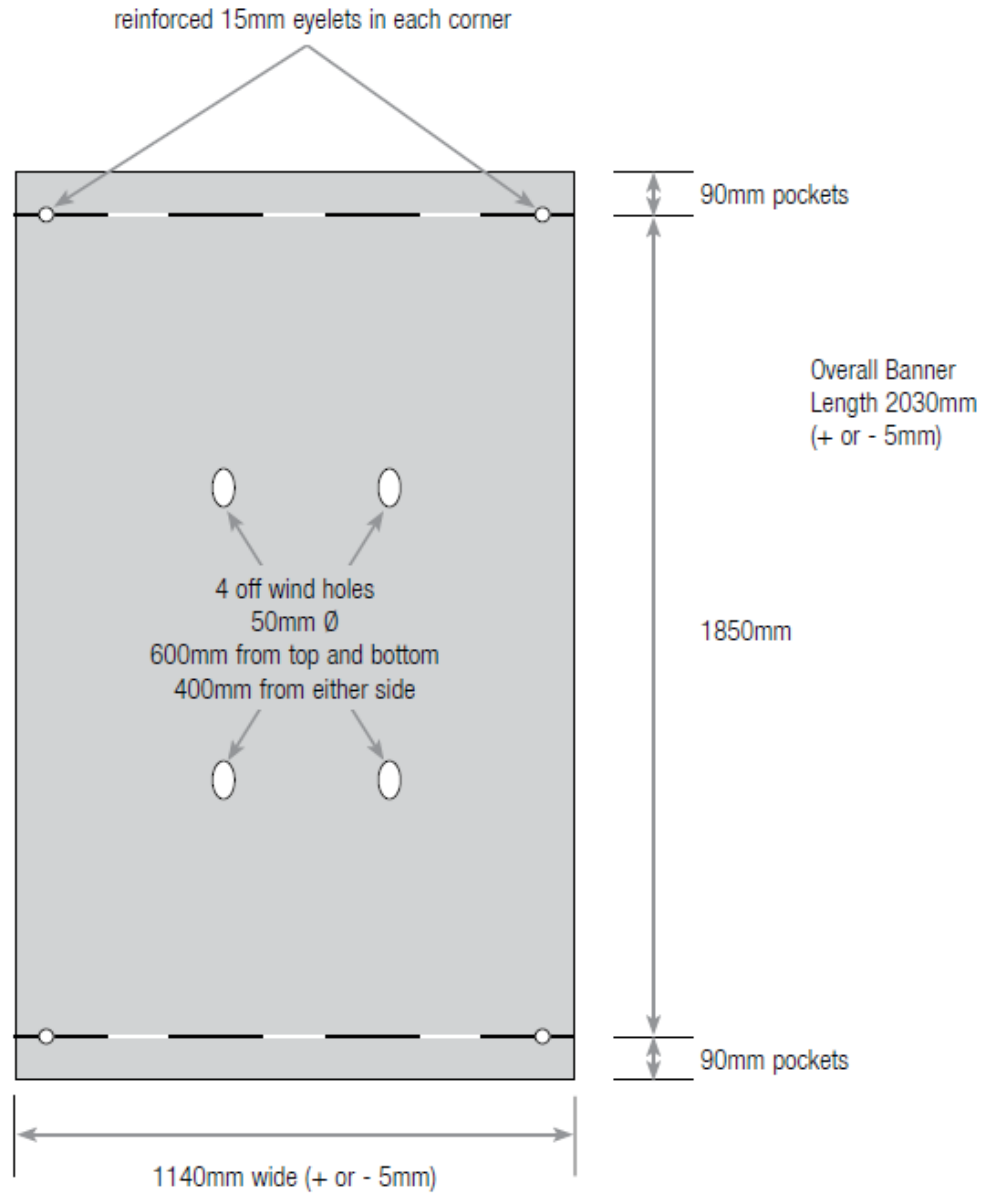

# Flag & Banner Design Guidelines

## City Banners Continued

### All Other Sites

\*Banners must be double sided

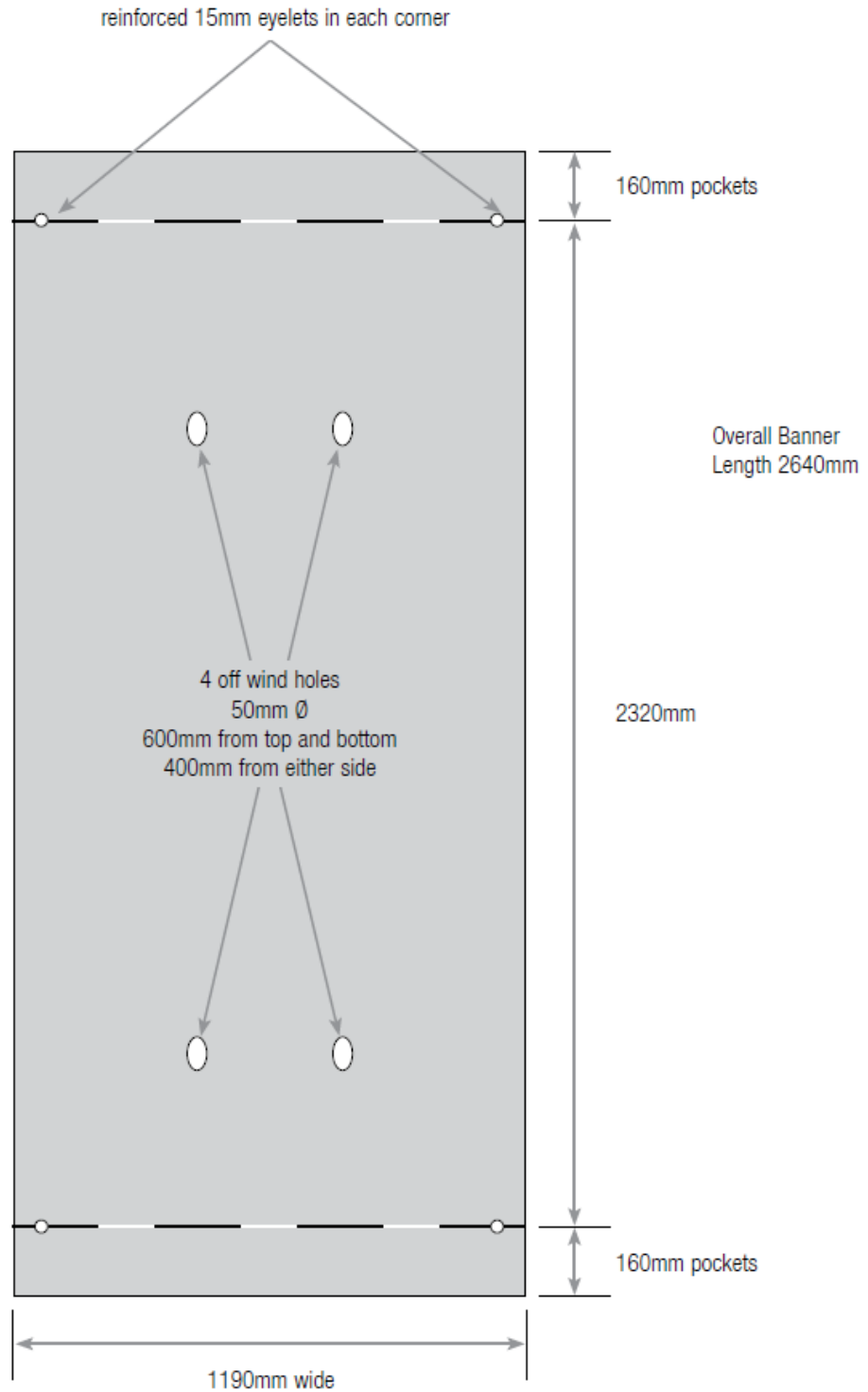

# Flag & Banner Design Guidelines

## Across Street Banners

### Gouger Street (All Sites)

\*Banners must be double sided

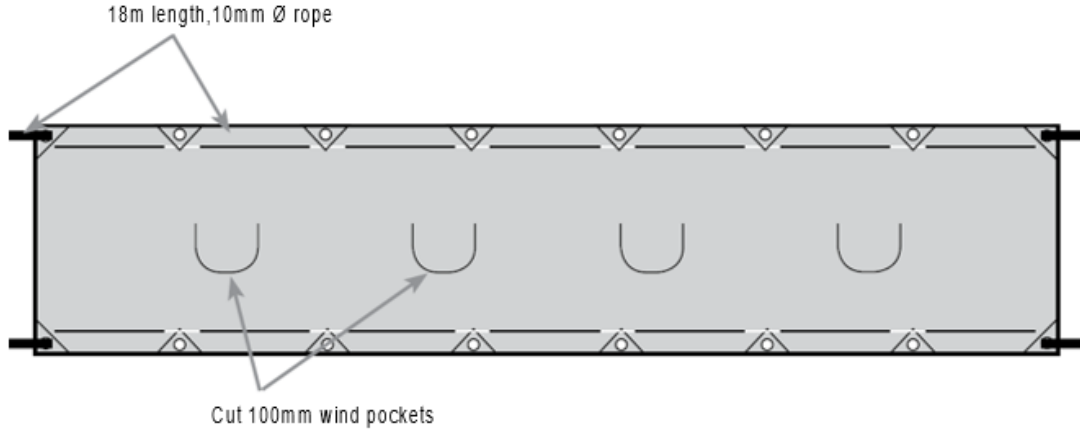

Banner length to be 8 metres and 1.8 metres wide. 10mm eyelets placed at 1 metre intervals in reinforced sewn patches. 10mm rope to be sewn in top and bottom of banner full length. Rope to be 18 metres long (e.g. 5 metres either end for securing banner).

## Flags

### Grote Street Portrait

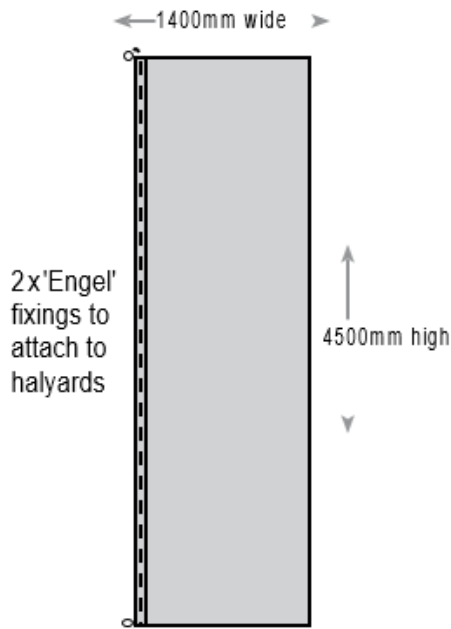

### Option (b) Contemporary Flag 4500mm high x 1400mm wide

Mirror image, knitted polyester, including all finishing to suit flag pole. Please advise if design includes flag extender pocket and hirers must supply their own flag extender rods.